

WILWOOD ENGINEERING

TRU-BAR BALANCE BAR BRAKE PEDAL INSTALLATION AND ADJUSTMENT GUIDE

DISC BRAKES SHOULD ONLY BE INSTALLED BY SOMEONE EXPERIENCED AND COMPETENT IN THE INSTALLATION AND MAINTENANCE OF DISC BRAKES **READ ALL WARNINGS**

WARNING

IT IS THE RESPONSIBILITY OF THE PERSON INSTALLING ANY BRAKE COMPONENT OR KIT TO DETERMINE THE SUITABILITY OF THE COMPONENT OR KIT FOR THAT PARTICULAR APPLICATION. IF YOU ARE NOT SURE HOW TO SAFELY USE THIS BRAKE COMPONENT OR KIT, YOU SHOULD NOT INSTALL OR USE IT. DO NOT ASSUME ANYTHING. IMPROPERLY INSTALLED OR MAINTAINED BRAKES ARE DANGEROUS. IF YOU ARE NOT SURE, GET HELP OR RETURN THE PRODUCT. YOU MAY OBTAIN ADDITIONAL INFORMATION AND TECHNICAL SUPPORT BY CALLING WILWOOD AT (805) 388-1188, OR VISIT OUR WEB SITE AT WWW.WILWOOD.COM. USE OF WILWOOD TECHNICAL SUPPORT DOES NOT GUARANTEE PROPER INSTALLATION. **YOU**, OR THE PERSON WHO DOES THE INSTALLATION MUST KNOW HOW TO PROPERLY USE THIS PRODUCT. IT IS NOT POSSIBLE OVER THE PHONE TO UNDERSTAND OR FORESEE ALL THE ISSUES THAT MIGHT ARISE IN YOUR INSTALLATION.

RACING EQUIPMENT AND BRAKES MUST BE MAINTAINED AND SHOULD BE CHECKED REGULARLY FOR FATIGUE, DAMAGE, AND WEAR.



Need Additional Information? Use Your
SmartPhone and Jump to Our Technical
Tips Section on Our Web Site.



WARNING

DO NOT OPERATE ANY VEHICLE ON UNTESTED BRAKES!
SEE MINIMUM TEST PROCEDURE WITHIN

ALWAYS UTILIZE SAFETY RESTRAINT SYSTEMS AND ALL OTHER AVAILABLE SAFETY EQUIPMENT WHILE OPERATING THE VEHICLE

IMPORTANT • READ THE DISCLAIMER OF WARRANTY INCLUDED IN THE KIT

NOTE: Some cleaners may stain or remove the finish on brake system components. Test the cleaner on a hidden portion of the component before general use.

General Information

Wilwood Tru-Bar pedals incorporate a fixed position trunnion bearing within the pedal arm, rather than the sliding mono-ball bearings used in traditional balance bar pedals. Bias is affected by changing the position of the pushrod attachment pivots relative to the fixed position centered trunnion bearing, rather than changing the pivot bearing position within the pedal arm relative to the master cylinder pushrod attachment pivots. This configuration design provides highly precise adjustment opportunities for fine tuning race prepped vehicles already equipped with suitably matched caliper piston and master cylinder bore sizes. It is not intended as the sole method of building bias into the system.

Pedal Installation and Assembly

Replacing Existing Sliding Mono-Ball Balance Bar Pedals

Wilwood Tru-Bar pedals have the same mounting dimensions and requirements as their sliding mono-ball counterparts. They can be bolted directly in place, without modifications, and use the same remote adjuster cables.

NOTE

When replacing a sliding mono-ball pedal of the same type, front to rear bias adjustments work the opposite of conventional ball type assemblies (if clockwise rotation was front bias, then with Tru-Bar pedals clockwise rotation will be rear bias).

New Installations

All pedals require a rigid mount connected to a non-flexing structural element within the vehicle. Sheet metal floor boards and firewalls alone are not sufficient to properly secure a pedal. If any deflection of the mounting is observed when firm pressure is applied to the pedal, the mount will require additional bracing to eliminate all flex.

Pedal mounting locations should be determined by driver comfort and preference in a location that does not interfere with other components. The static brake pedal height should also be positioned closer to the driver than the accelerator pedal to prevent inadvertent application of the throttle during braking cycles.

A positive return spring and pedal stop is recommended for all installations. Figure 1 shows a properly configured pedal stop. Final adjustments of the pushrod lengths and pedal stop position must assure that the master cylinder pistons are able to fully return and completely release the brake pressure. There should never be any amount of preload on the master cylinders. If the master cylinder piston is not allowed to fully retract when the brake pedal is not applied, the primary inside seal will not return past the small pressure relief hole (visible within the master cylinder reservoir on some master cylinders). This can cause excessive residual line pressure and contribute to brake drag and an overheating condition, see Figure 1, Detail "A".

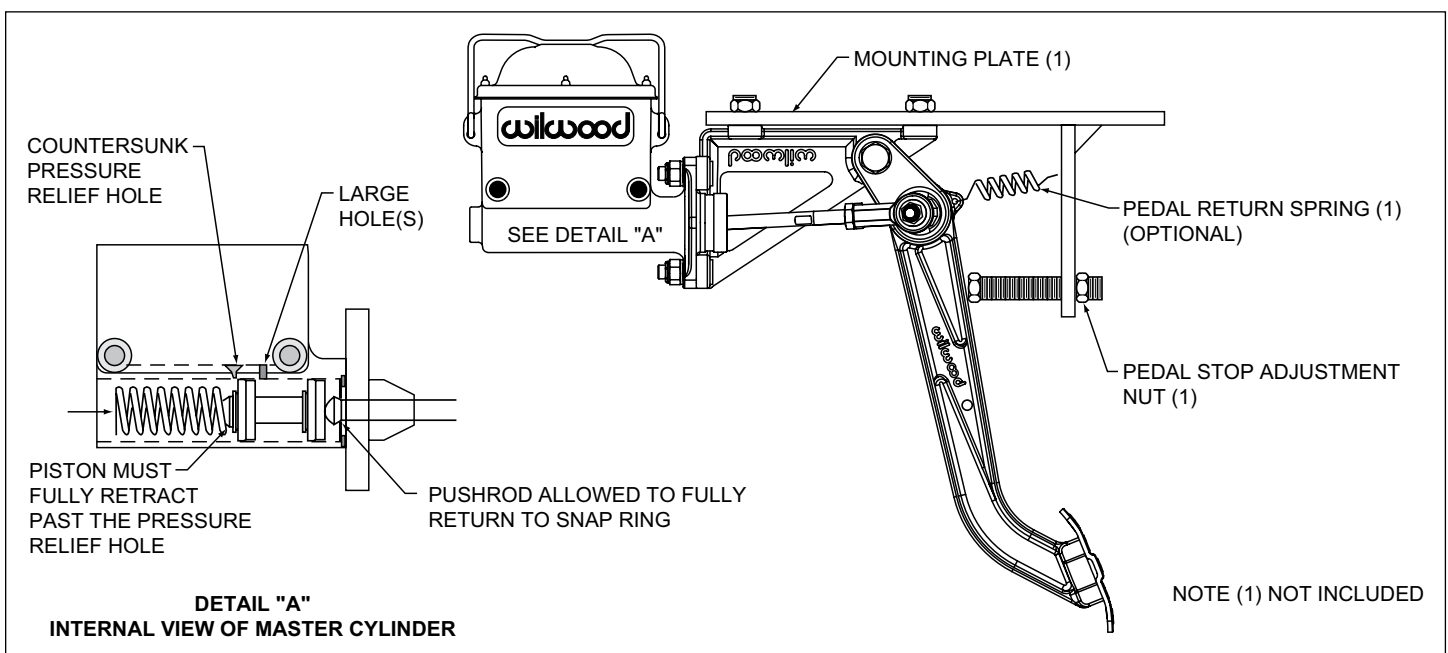

Pedal Installation and Assembly (Continued)

Master Cylinder Installation and Pushrod Adjustments

Prior to attaching the master cylinder pushrods to the spherical bearing pivots on the balance bar, adjust the threaded rod to a centered position with an equal amount of the bar protruding from both sides of the pedal arm.

For the initial bleeding and adjustment of the pedal stop position, the pushrod lengths can be set to an equal length. Additional pushrod length adjustments to compensate for differences in master cylinder stroke can be done after the system has been bled. See Figure 2.

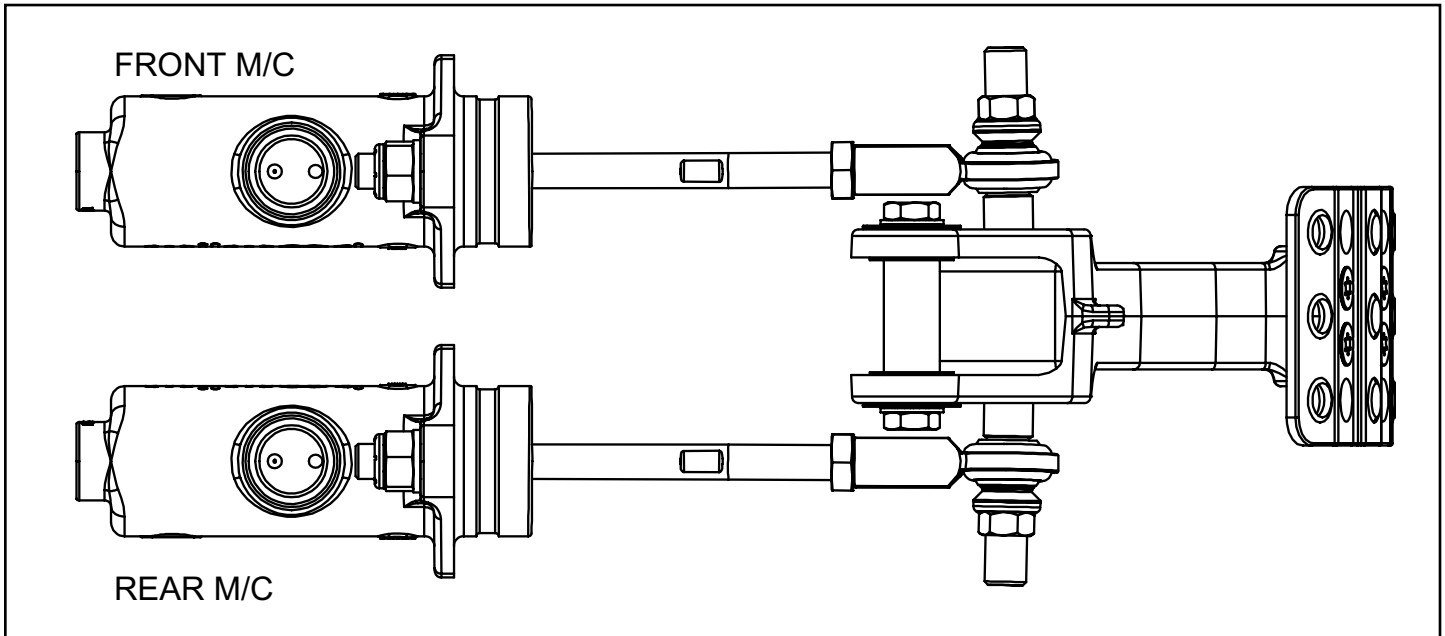

Figure 2. Initial Balance Bar Lever Adjustment

Bleeding the System

ALWAYS bench bleed new master cylinders prior to connecting the fluid lines. Failure to properly purge all air from the master cylinder piston chamber will result in the inability to bleed the system with the lines attached. Bench bleeding new master cylinders should be done prior to installation by attaching a short length of clear line to the master cylinder outlet and submerging it below fluid level in the reservoir. SLOWLY make full strokes of the master cylinder until all air has been eliminated from the line, and no air bubbles are visible from out of the fluid ports in the bottom of the reservoir when the piston is fully released. Replace the outlet line with a plug while the master cylinders are being installed to prevent fluid from spilling out. Once the cylinders are secured to the pedal, remove the plugs and connect the brake lines.

For manual bleeding of the system using the pedal, the front and rear fluid circuits should be bled simultaneously allowing both master cylinders to operate together without any bind in the balance bar pivots or bearing. DO NOT attempt to fully adjust the balance bar to one side or the other and bleed only one cylinder at a time. This can potentially cause damage to the bar, bearings, and master cylinders.

Operational Pushrod Length Adjustment

In those few instances where a 50/50 bias system with the same caliper piston sizes at all four wheels and equal size master cylinders front and rear are employed, set the pushrod lengths equal as shown in Figure 2.

For all other vehicles with a split bias system, the pushrod lengths will require being set to different lengths to compensate for the differences in master cylinder piston stroke that occurs in a split bias system.

Figure 3 shows a typical rear wheel drive, front biased system as used on pavement oval track or road course cars, and the subsequent changes in the balance bar that occur through the full range of pedal travel. In this scenario, the front master cylinder pushrod is adjusted longer. For other configurations using a higher rear bias, the pushrod length settings would be the opposite.

Pedal Installation and Assembly (Continued)

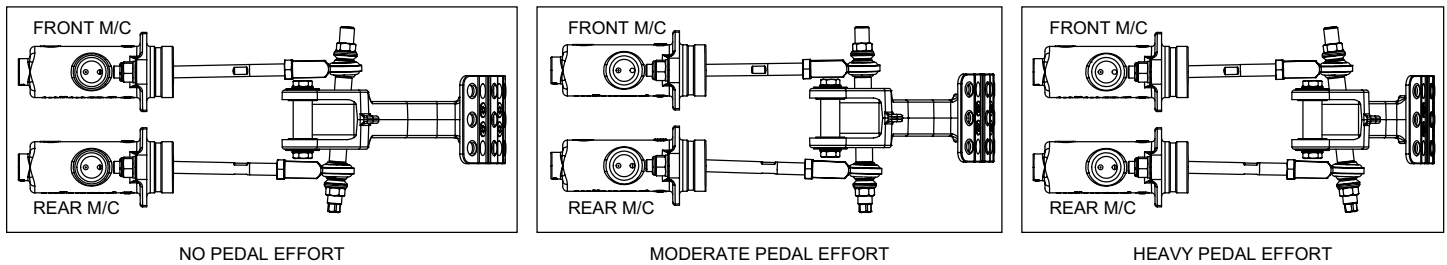

NOTE:
THE PUSHROD ADJUSTMENT DEPICTED IN THIS FIGURE IS REPRESENTATIVE OF A TYPICAL ASPHALT APPLICATION.
THAT IS, LARGE CALIPER PISTONS IN FRONT, SMALL CALIPER PISTONS IN THE REAR.

Figure 3. Balance Bar Lever Adjustment

The amount of difference in the adjusted pushrod lengths will be determined by the overall difference in volume displacement between the front and rear circuits. The pushrod length of the higher volume circuit must be adjusted longer to prevent binding in the pedal pivot bearing or pushrod spherical bearing pivots through the entire range of pedal travel.

Observe the differences in stroke between the front and rear cylinders, and then adjust the pushrods to equalize the amount of angle change in the balance bar from fully released, to intermediate, to heavy pedal effort. The balance bar should be square and perpendicular to the master cylinder pushrods at the halfway down point.

When making adjustments to set the pushrod lengths, the pedal should be fully retracted against the stop. As one pushrod is adjusted longer, the other pushrod must be adjusted an equal amount shorter to prevent either from applying any amount of pressure to either master cylinder.

NOTE: Pushrod length does not affect front to rear bias or the timing of the circuits in any way. The bias can only be affected by moving the balance bar position. Do not attempt to adjust the pushrod length for those purposes.

Remote Adjuster Cable Attachment

It is not necessary to use a jam nut when attaching the remote adjuster cable. The cable end coupling nut should be tightened onto the balance bar until it bottoms out. Wilwood remote adjuster cable P/N 340-4990 is recommended for use with all pedals.

Affecting Bias with the Balance Bar

The Tru-Bar balance bar affects front to rear bias by changing the position of the spherical bearing pushrod pivots relative to the fixed position centered trunnion bearing. As the balance bar is rotated, the spherical pushrod pivot bearing that moves closer to the pedal pivot bearing receives more leverage and a higher brake bias than the bearing that moves farther away. To prevent excessive side loading of the master cylinder pistons in the bores, and potential binding within the bearings, balance bar adjustments should be limited to 4 turns from center in either direction. If the vehicle requires additional bias adjustment, a change in master cylinder size, caliper piston size, or the use of an inline proportioning valve may be necessary.

NOTE: The Tru-Bar balance bar incorporates stop spacers to prevent over adjustment. Excessive adjustments off center can lead to premature master cylinder piston and bore wall wear, as well as binding and damage to the bar itself. Therefore do not remove the stop spacers from the balance bar.

Pedal Installation and Assembly (Continued)

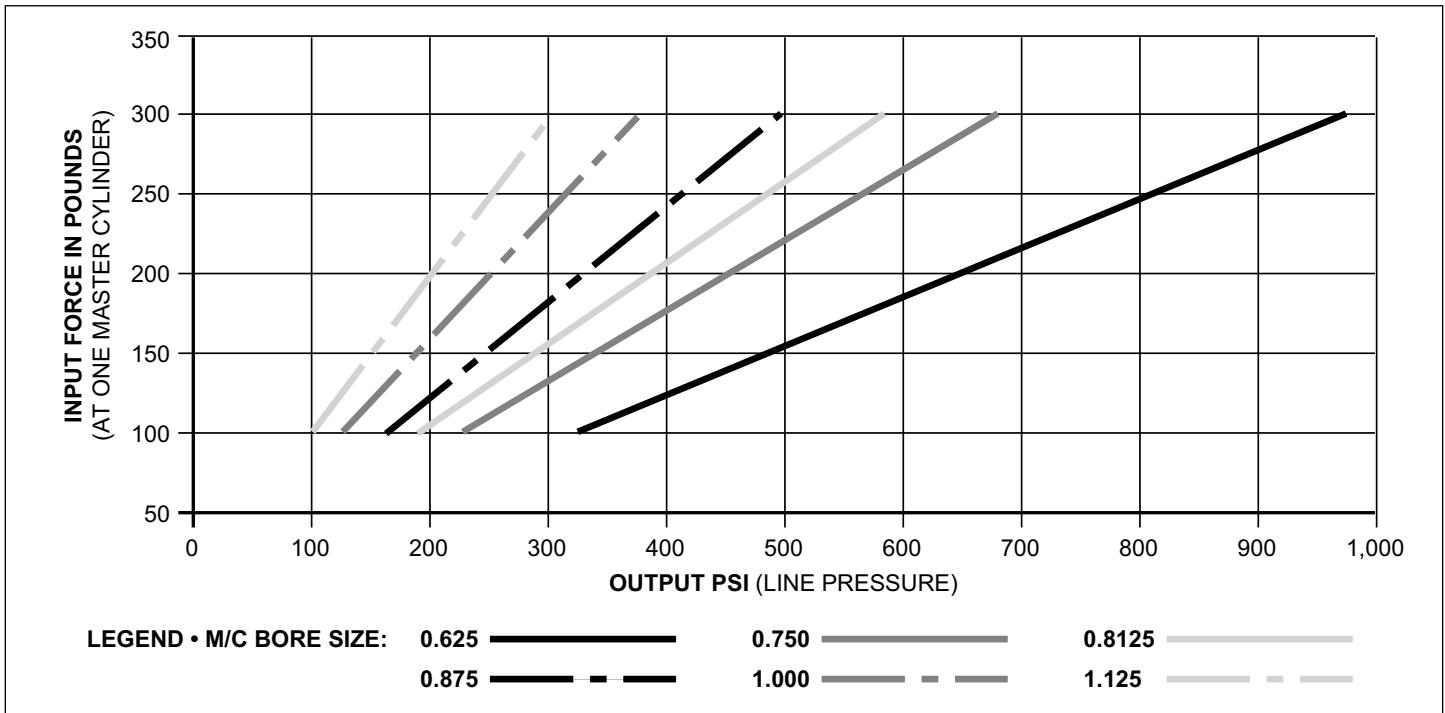

Figure 4. Input Force vs Output PSI

Tuning and Adjusting Tips

Pressure gauges can provide invaluable data for system set up, evaluation, and adjustment. Not only can they accurately record changes made to bias before and after an event, they can provide the best indication of balance bar position relative to center. The pressure gauges can also indicate problems with pushrod adjustment and travel if the front and rear pressures do not rise at a consistent and proportionate rate. The graph below illustrates pressure output from different master cylinder bore sizes based on input.

NOTES:

- Master cylinder bore area is determined by (bore x bore) x .785 (ex. 3/4" bore = .750 in x .750 in x .785 in² = .441 in²)
- Total input force is a function of (pedal effort x pedal ratio) (ex. 100 lb x 5:1 = 500 lb)
- Total input force is proportionately split between the master cylinders based on the bar position (Centered balance bar = 50% of total input force on each master cylinder (ex. 500 lb x .50 [centered balance bar] = 250 lb on one master cylinder).
- Master cylinder output pressure is determined by (input force / bore area) (ex. 250 lb / .441 in² = 566 PSI)

Use of Inline Adjustable Proportioning Valves in Conjunction with a Balance Bar Pedal

Adjustable proportioning valves can provide an added degree of adjustment by affecting a diminished rate of pressure gain at only the higher pressure, higher pedal effort braking zones. This can be beneficial when the balance bar setting might cause wheel lock up in the high pressure brake zones when adjusted to maximize brake balance or bias in the low and intermediate pressure brake zones.

Brake Testing

**WARNING • DO NOT DRIVE ON UNTESTED BRAKES
BRAKES MUST BE TESTED AFTER INSTALLATION OR MAINTENANCE
MINIMUM TEST PROCEDURE**

- Make sure pedal is firm: Hold firm pressure on pedal for several minutes, it should remain in position without sinking. If pedal sinks toward floor, check system for fluid leaks. DO NOT drive vehicle if pedal does not stay firm or can be pushed to the floor with normal pressure.
- At very low speed (2-5 mph) apply brakes hard several times while turning steering from full left to full right, repeat several times. Remove the wheels and check that components are not touching, rubbing, or leaking.
- Carefully examine all brake components, brake lines, and fittings for leaks and interference.
- Make sure there is no interference with wheels or suspension components.
- Drive vehicle at low speed (15-20 mph) making moderate and hard stops. Brakes should feel normal and positive. Again check for leaks and interference.
- Always test vehicle in a safe place where there is no danger to (or from) other people or vehicles.
- Always wear seat belts and make use of all safety equipment.

Connect with Wilwood

Wilwood Facebook



Wilwood Instagram



Wilwood Twitter



Wilwood YouTube

